

DollyCraneHD™

DollyCrane™

INSTRUCTION MANUAL

FloatCam



Index:

p. 1-14 DollyCrane

p. 15-30 DollyCraneHD

DollyCrane Contents

Contents: Large Case

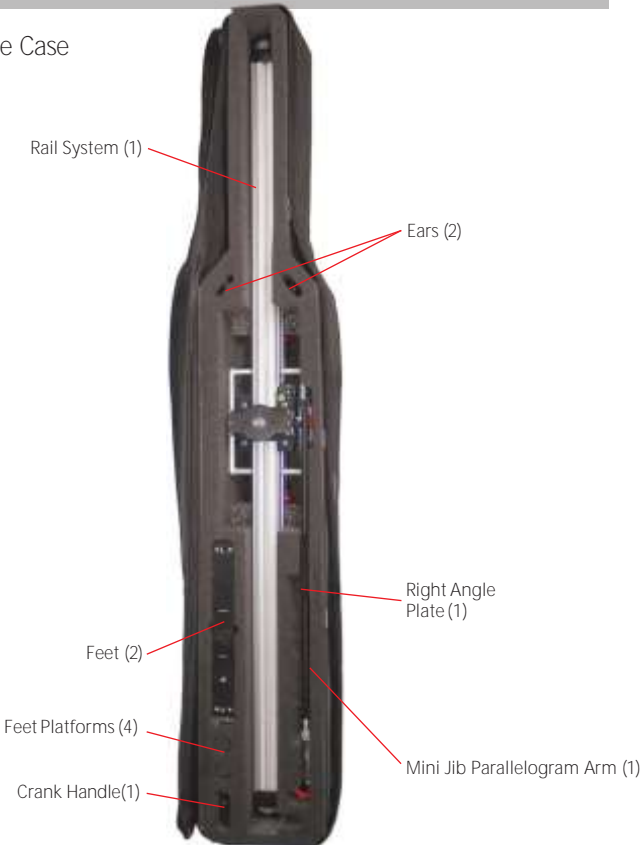

Contents: Small Case

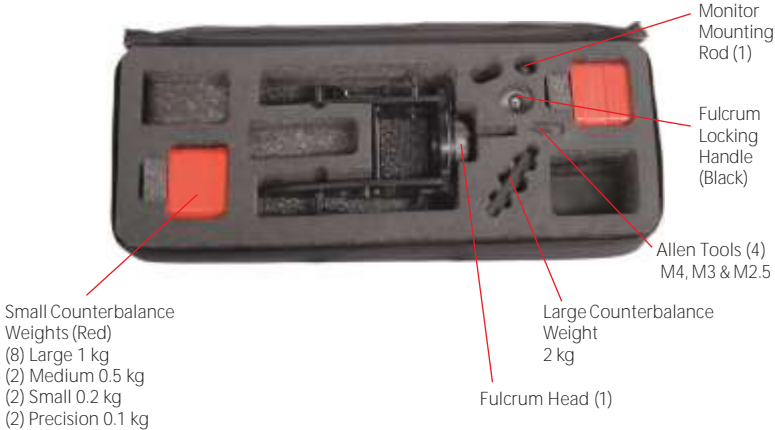

DollyCrane **Setup & Counterbalance**



FIG 1. A flat plate fluid head and heavy-duty (35kg min) tripod with 100mm bowl must be used with this system.



FIG 2. Insert the fulcrum head and level it accordingly.



FIG 3. Secure the fulcrum head using the long black handle with female threaded hole.



FIG 4. Remove the black 'kip' handles on each side fulcrum.



FIG 5. Insert the rail onto the top of the fulcrum with the red 'kip' handle on the same side as the DollyCrane script.



FIG 6. The 'smile' quadrant of the rail system should be on the outside of the fulcrum head.



FIG 7. Secure the rail system with the two black 'kip' handles.



FIG 8. Mount your flat plate fluid head onto the 3/8" threaded stud on the rail platform.



FIG 9. Tighten the flat plate fluid head to the rail platform until it is secure.



FIG 10. Mount your camera package to the fluid head (camera package and fluid head not to exceed 12kg).

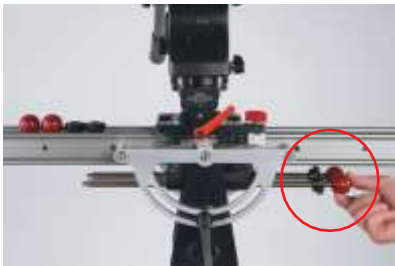

FIG 11. Remove the black nuts and the red protective balls from the counterbalance sled.



FIG 12. Add counterweight to the sled to equal the weight of the camera and fluid head package.



FIG 13. Reattach the black nuts for weight security.



FIG 14. Loosen the red slider brake.



FIG 15. Slide the camera away from the center.



FIG 16. Tighten the red slider brake and place red protective balls above the counterweight.

DollyCrane **Setup & Counterbalance**

CONT'D



FIG 17. Loosen the black 'kip' handles on each side of the fulcrum near the rail quadrant.



FIG 18. Hold both sides of the rail and check the balance.



FIG 19. You may need to add or subtract counterbalance weight for precision. Repeat steps 11-18 if rebalancing is needed.



FIG 20. For camera and fluid head packages weighing more than 10kg, add the large counterweight to the bottom of the weight sled.



FIG 21. Use the allen key and screws provided to securely mount the black counterweight.



FIG 22. Once the system has been accurately balanced, you may begin shooting.



FIG 23. For slow sliding movements you may insert the crank handle provided onto the crank spline.



FIG 24. **Remember:** Remove crank handle when not in use while operating as it will cause shaking of the rail.



FIG 25. To angle the rail for diagonal slides, move the camera to the middle of the rail.



FIG 26. Apply the red slider brake handle.



FIG 27. Loosen the black 'kip' handles on each side of the fulcrum head.



FIG 28. Position the rail in the desired position.



FIG 29. Tighten the black 'kip' handles on each side of the fulcrum head.



FIG 30. Hold the camera with one hand and loosen the red 'kip' handle under the black circular adjustment knob.



FIG 31. While holding the camera, pull out the black circular adjustment knob and position the camera in a level or desired position.



FIG 32. You will have to pull the black circular adjustment knob with great force to achieve this.

DollyCrane **Setup & Counterbalance**

CONT'D



FIG 33. Once you have achieved the desired position, tighten the red 'kip' handle.



FIG 34. Release the red slider break.



FIG 35. You are now ready to move the camera up and down the rail with ease.

DollyCrane **SliderLowProfileSetup**



FIG 36. Insert the threaded platforms into the feet.



FIG 37. Attach the feet to each end of the rail using the screws provided.



FIG 38. Each end of the rail should have one foot and two threaded platforms. Adjust threaded platforms to desired height.

IMPORTANT:

You must complete the counterbalance procedure in the first section of this manual before completing this setup.



FIG 39. Adjust threaded platforms to the desired height.



FIG 40. The threaded platforms have swiveling feet, which allows the user to change the angle of the low profile slider.

DollyCrane **MiniJibSetup**

CAUTION: You must complete the counterbalance procedure in the first section of this manual before completing this setup.



FIG 41. Level the rail and the counter-balanced fluid head and camera package.



FIG 42. With both black 'kip' handles tightened on each side of the fulcrum head, slide the camera package to the end of the rail opposite the crank spline.



FIG 43. Tighten the slider brake once the camera has been moved to the end of the rail.



FIG 44. Install the parallelogram arm located in the large case by completing the following.



FIG 45. Install the end of the parallelogram arm opposite the small lever with the red 'kip' handle onto the focal point adjustment located on the fulcrum head.



FIG 46. Turn the knob on the focal point adjustment to reposition the end of the parallelogram arm so that it is on the top of the adjustment.



FIG 47. Attach the opposite side of the parallelogram arm to the camera platform by inserting the red 'kip' handle bolt into the threaded hole. **Do not thread all the way.**



FIG 48. The lever with red 'kip' handle should be perpendicular to the rail. This will ensure parallel camera movement to the ground.



FIG 49. You may need to adjust the length of the parallelogram arm to adjust framing.



FIG 50. Use the adjusting hand grip on the parallelogram arm to accomplish this.



FIG 51. Complete tightening process with the red 'kip' handle. Ensure the teeth in the middle of the camera platform are fully disengaged and that the nipples on the arm's lever have fully met the holes on the platform.



FIG 52. Release the red 'kip' handle underneath the black adjustment knob.



FIG 53. Release the black 'kip' handles on each side of the fulcrum head to activate the mini jib function.



FIG 54. As the mini jib moves up and down, the camera should stay parallel with the ground.

DollyCrane **MiniJibSetup** CONT'D



FIG 55. If you desire to keep an object within the camera frame, reposition the focal point adjustment to the bottom.



FIG 56. The mini jib will now focus on the framed object as the system elevates and descends. You may need to use the adjusting hand grip depending on your distance between the camera and the point of interest.



FIG 57. Loosening up the fulcrum brake handles will allow 360 degree rotations around the vertical access of the tripod.



FIG 58. To disassemble the mini jib, tighten the red 'kip' handle underneath the black adjustment knob.



FIG 59. Remove the parallelogram lever by releasing the red 'kip' handle.



FIG 60. Once the parallelogram arm has been removed from the camera platform side, remove the opposite end on the fulcrum head.

DollyCrane **MountingMonitor**



FIG 61. To mount a monitor on the fulcrum, attach one of the ears with the rubber disk facing out.



FIG 62. Attach the black mounting rod by screwing it onto the ear.



FIG 63. Mount your ball head of choice to the 1/4" end of the rod.



FIG 64. Add the monitor to the ball head and lock it off to desired position.

DollyCrane TowerSetup



FIG 65. Complete vertical tower configuration.

CAUTION:

You must complete the counterbalance procedure in the first section of this manual before completing this setup.



FIG 66. Add one of the feet with the threaded platforms to the side opposite the crank spline. **Use the holes on the foot labeled 'Vertical Feet'** and make sure the long side of the foot is facing outward.



FIG 67. Add the two ears to the base of the fulcrum using the threaded knobs. Make sure the rubber disks on the ears face outward.



FIG 68. Add the rail in the vertical position **using the black 'kip' handles from the fulcrum**, threading them through the slider quadrant and into the ears previously mounted on the fulcrum.



FIG 69. To mount the right angle plate, line the holes on the short side of the plate with the hole pattern on the slider platform.



FIG 70. The long side of the plate should face up. Use the screws provided to securely mount the plate.



FIG 71. Mount your flat plate fluid head to the top of the right angle plate using the screw provided.



FIG 72. Mount your camera package to the fluid head to complete vertical tower configuration.



FIG 73. Completed vertical tower configuration.

DollyCrane **Additional Info**



FIG 74. The counterweight rods must be protected with the red balls provided for safety purposes for those in close proximity to the DollyCrane.



FIG 75. Affix the optional stepper motor to the crank spline.



FIG 76. The stepper motor is operated with a microprocessor, allowing the user to operate the slider and tower configurations. Time lapse, manual movement and programmable repeated movements are possible with the use of these accessories.



FIG 77. The wheel tension is set by the manufacturer. With time and frequency, it may be necessary to adjust the tension with the M2.5 allen key provided in the system.

DollyCraneHD Contents

Contents: Large Case

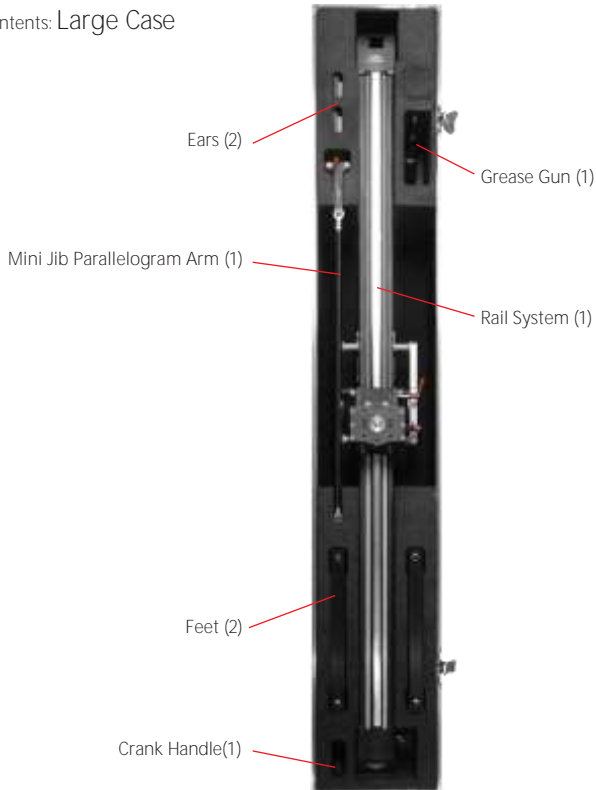

Contents: Small Case

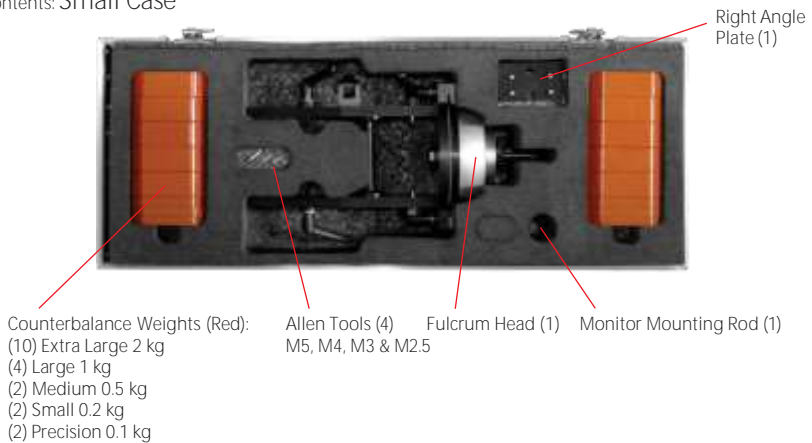

Counterbalance Weights (Red):
 (10) Extra Large 2 kg
 (4) Large 1 kg
 (2) Medium 0.5 kg
 (2) Small 0.2 kg
 (2) Precision 0.1 kg

Allen Tools (4)
 M5, M4, M3 & M2.5

Fulcrum Head (1)

Monitor Mounting Rod (1)

Right Angle
 Plate (1)

DollyCraneHD Overview

The DollyCrane HD sets up virtually the same as the DollyCrane, however there are some differences that must be taken into account when assembling.

The following pages should be reviewed prior to final assembly to ensure product functionality and personal safety. Due to the mass of the components, it is recommended that assembly should be assisted by a second person.



The Heavy-Duty Dollycrane comes standard with hard rolling flight cases with protective foam inserts.



Safety lock: The DollyCrane HD comes standard with a safety lock mechanism and various holes on the bottom of the rail for locking the sled in multiple positions. Be sure to engage the safety lock for transport and when major re-positioning of the rail is required. e.g. flipping the rail from horizontal to vertical.

Failure to engage the safety lock during transport and/or rail re-positioning may lead to injury or death.



Brake system: In addition to the safety lock, the system comes standard with brake on the camera platform. Use the red handle to engage the brake when the system is not in use, in transit and when repositioning the rail.

Note: The brake is not meant to be used for pressure or dampening adjustments for the sliding functions of the system.

DollyCraneHD Setup & Counterbalance



FIG 1. The DollyCraneHD requires a heavy-duty 150mm bowl or Mitchell tripod with a minimum payload of 95kg.



FIG 2. Insert the fulcrum head and level it accordingly.



FIG 3. Secure the fulcrum head using the handle with female threaded hole.



FIG 4. Remove the black 'kip' handles on each side fulcrum.



FIG 5. Insert the rail onto the top of the fulcrum with the red 'kip' handle on the same side as the DollyCrane script.



FIG 6. The 'smile' quadrant of the rail system should be on the outside of the fulcrum head.



FIG 7. Secure the rail system with the two black 'kip' handles.



FIG 8. Mount your flat plate fluid head onto the 3/8" threaded stud on the rail platform.



FIG 9. Tighten the flat plate fluid head to the rail platform until it is secure.



FIG 10. Loosen the red slider brake.

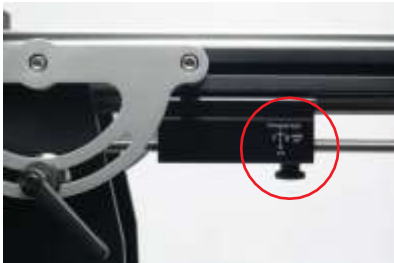

FIG 11. Loosen the safety lock and move the dolly to the middle of the rail. Then lock the dolly using the red slider brake.



FIG 12. Mount your camera package to the fluid head (camera package and fluid head not to exceed 32kg).



FIG 13. Remove the black nuts and the red protective balls from the counterbalance sled.



FIG 14. Add counterweight to the sled to equal the weight of the camera and fluid head package.



FIG 15. Reattach the black nuts for weight security.



FIG 16. Loosen the red slider brake.

DollyCraneHD Setup & Counterbalance

CONT'D



FIG 17. Slide the camera away from the center.



FIG 18. Tighten the red slider brake.



FIG 19. Loosen the black 'kip' handles on each side of the fulcrum near the rail quadrant.



FIG 20. Hold both sides of the rail and check the balance.



FIG 21. You may need to add or subtract counterbalance weight for precision. Repeat steps 13-20 if rebalancing is needed.



FIG 22. Lock the counterbalance using the black nuts and red balls.



FIG 23. Once the system has been accurately balanced, you may begin shooting.



FIG 24. For slow sliding movements you may insert the crank handle provided onto the crank spline.



FIG 25. **Remember:** Remove crank handle when not in use while operating as it will cause shaking of the rail.



FIG 26. To angle the rail for diagonal slides, move the camera to the middle of the rail.



FIG 27. Apply the red slider brake handle.



FIG 28. Loosen the black 'kip' handles on each side of the fulcrum head.



FIG 29. Position the rail in the desired position.



FIG 30. Tighten the black 'kip' handles on each side of the fulcrum head.



FIG 31. Hold the camera with one hand and **loosen the red 'kip' handle under the black circular adjustment knob.**



FIG 32. While holding the camera, pull out the black circular adjustment knob and position the camera in a level or desired position.

DollyCraneHD Setup & Counterbalance

CONT'D



FIG 33. Once you have achieved the desired position, tighten the red 'kip' handle.



FIG 34. Release the red slider break.



FIG 35. You are now ready to move the camera up and down the rail with ease.



DollyCraneHD SliderLowProfileSetup



FIG 36. Insert the feet to each end of the rail.



FIG 37. Lock the feet using the screws provided.



FIG 38. Each end of the rail should have one foot and two threaded platforms. Adjust threaded platforms to desired height.

CAUTION:

You must complete the counterbalance procedure in the first section of this manual before completing this setup.



FIG 39. Adjust threaded platforms to the desired height.



FIG 40. The threaded platforms have swiveling feet, which allows the user to change the angle of the low profile slider.

DollyCraneHD MiniJibSetup

CAUTION: You must complete the counterbalance procedure in the first section of this manual before completing this setup.



FIG 41. Level the rail and the counterbalanced fluid head and camera package.



FIG 42. With both black 'kip' handles tightened on each side of the fulcrum head, slide the camera package to the end of the rail opposite the crank spline.



FIG 43. Tighten the slider brake once the camera has been moved to the end of the rail.



FIG 44. Install the parallelogram arm located in the large case by completing the following.



FIG 45. Install the end of the parallelogram arm opposite the small lever with the red 'kip' handle onto the focal point adjustment located on the fulcrum head.



FIG 46. Attach the opposite side of the parallelogram arm to the camera platform by inserting the red 'kip' handle bolt into the threaded hole. **Do not thread all the way.**



FIG 47. The lever with red 'kip' handle should be perpendicular to the rail. This will ensure parallel camera movement to the ground.

FIG 48. Complete tightening process with the red 'kip' handle. **Ensure the teeth in the middle of the camera platform are fully disengaged and that the nipples on the arm's lever have fully met the holes on the platform.**



FIG 49. Release the red 'kip' handle underneath the black adjustment knob.



FIG 50. Release the black 'kip' handles on each side of the fulcrum head to activate the mini jib function.



FIG 51. As the mini jib moves up and down, the camera should stay parallel with the ground. Loosening up the fulcrum brake handles will allow 360 degree rotations around the vertical axis of the tripod.



FIG 52. To disassemble the mini jib, tighten the red 'kip' handle underneath the black adjustment knob.



FIG 53. Remove the parallelogram lever by releasing the red 'kip' handle.



FIG 54. Once the parallelogram arm has been removed from the camera platform side, remove the opposite end on the fulcrum head.

DollyCraneHD TowerSetup

CAUTION:
You must complete the counterbalance procedure in the first section of this manual before completing this setup.



FIG 55. Complete vertical tower configuration.



FIG 58. Be sure to engage the safety lock on the bottom of the weight sled as well as the slider brake on the camera platform. Just like the DollyCrane, remove your camera package and fluid head, flip the rail vertically off the fulcrum, rest the rail on the foot, mount the ears to the fulcrum and secure the rail on the ears using the black kip handles.



FIG 56. Add one of the feet with the threaded platforms to the side opposite the crank spline. Make sure the long side of the foot is facing outward.



FIG 57. Add the two ears to the base of the fulcrum using the threaded knobs. Make sure the rubber disks on the ears face outward.

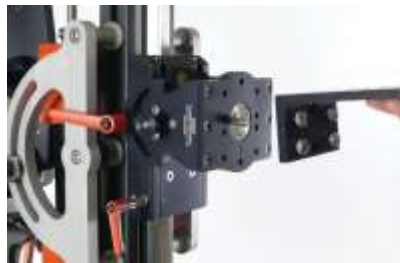

FIG 59. To mount the right angle plate, line the holes on the short side of the plate with the hole pattern on the slider platform.



FIG 60. The long side of the plate should face up. Use the screws provided to securely mount the plate.



FIG 61. Mount your flat plate fluid head to the top of the right angle plate using the screw provided.



FIG 62. Mount your camera package to the fluid head to complete vertical tower configuration. You may release the safety lock and slider brake to make vertical dolly shots with ease.



FIG 63. Completed vertical tower configuration.

DollyCraneHD Mounting Monitor



FIG 64. To mount a monitor on the fulcrum, attach one of the ears with the rubber disk facing out.



FIG 65. Attach the black mounting rod by screwing it onto the ear.



FIG 66. Mount your ball head of choice to the 1/4" end of the rod.



FIG 67. Add the monitor to the ball head and lock it off to desired position.

DollyCraneHD Additional Info



FIG 68. The counterweight rods must be protected with the red balls provided for safety purposes for those in close proximity to the DollyCrane.



FIG 69. Affix the optional stepper motor to the crank spline.



FIG 70. The motor is operated with a microprocessor, allowing the user to operate the slider and tower configurations. Time lapse, manual movement and programmable repeated movements are possible with the use of these accessories.

DollyCraneHD Maintenance

With time and frequency, it is necessary to grease dolly and counterweight bearings.

Important:

The rails have to be covered with a thin layer of grease to prevent corrosion.

Use Texaco Multifak EP2 grease and a standard grease gun (included) to grease the system.

Warranty does not cover corroded rails. It is the owner responsibility to properly grease and maintain the DollyCrane HD rails and bearings system.



FIG 71. Remove the cover of the dolly bearings using the allen key provided.



FIG 72. Grease the dolly bearings using the grease gun provided.



FIG 72. Remove the cup of the counterweight bearings.



FIG 73. Grease the counterweight bearings using the grease gun provided.

Liability: The DollyCrane should only be operated by qualified personnel. The DollyCrane braking system was designed to be used when the system has been precision counterbalanced. The DollyCrane is not meant to be used with loads over twelve kilograms. Exceeding this weight capacity may trigger system malfunction, which may result in injury, death or may damage equipment affixed or within close proximity of the DollyCrane. FloatCam has made diligent effort to illustrate and describe the products and components in this manual accurately however, illustrations and descriptions including descriptions of dimensions and weight, are for identification purposes only, and are not warranties that the products will conform to the illustrations or descriptions. Descriptions of output and other performance levels of our product are based on normal use conditions, as well as installation and operation by qualified persons. However, these descriptions are not warranties. Product performance or output may also be affected by state and local regulations on sales, construction, installation and/or use of products. In no event shall our company, officers, directors, employees or agents be responsible for any direct, indirect, punitive, special, incidental or consequential damages, however, it arises, whether in an action for negligence or some other action, or arising out of or in connection with the comments or advice provided by this application.

Warranty: FloatCam products are warranted against defects for one year from date of purchase. Within this period of time FloatCam will repair it without charge for labor or parts. Warranty does not cover transportation costs nor does it cover a product subjected to misuse or accidental damage. Warranty does not cover corroded rails. Warranty repairs are subjected to inspection and evaluation by FloatCam.

FloatC::am

Camera Motion Systems

Wybickiego 42 81-842 Sopo Poland
+48.604.359.185 floatcam@floatcam.eu +48.58.551.21.87

For more information visit